

BEFORE THE ILLINOIS POLLUTION CONTROL BOARD

John and Jennifer Fehr-Rankin)
(Property Identification Number) PCB 10-
39-32-100 004) (Tax Certification)
)

NOTICE

Clerk
Illinois Pollution Control Board
James R. Thompson Center
100 West Randolph Street, Suite. 11-500
Chicago, Illinois 60601

Steve Santarelli
Illinois Department of Revenue
101 West Jefferson
Post Office Box 19033
Springfield, Illinois 62794

John and Jennifer Fehr
1450 E. 000N Road
Rankin, Illinois 60960

PLEASE TAKE NOTICE that I have today filed with the Office of the Clerk of the Pollution Control Board an **APPEARANCE AND RECOMMENDATION** of the Illinois Environmental Protection Agency, a copy of which is herewith served upon you.

ENVIRONMENTAL PROTECTION AGENCY
OF THE STATE OF ILLINOIS

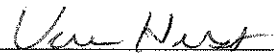
By: 
Vera Herst
Assistant Counsel
Division of Legal Counsel

DATED: April 13, 2010

Illinois Environmental Protection Agency
1021 North Grand Avenue East
Post Office Box 19276
Springfield, Illinois 62794-9276
(217) 782-5544

THIS FILING IS SUBMITTED ON RECYCLED PAPER

BEFORE THE ILLINOIS POLLUTION CONTROL BOARD

John and Jennifer Fehr-Rankin)
(Property Identification Number) PCB 10-
39-32-100 004) (Tax Certification)
)

A P P E A R A N C E

The undersigned, as one of its attorneys, hereby enters an APPEARANCE on behalf of Respondent,
Illinois Environmental Protection Agency.

ILLINOIS ENVIRONMENTAL PROTECTION AGENCY

By: Vera Herst
Vera Herst
Assistant Counsel
Division of Legal Counsel

DATED: April 13, 2010
Illinois Environmental Protection Agency
1021 North Grand Avenue East
Post Office Box 19276
Springfield, Illinois 62794-9276
(217)782-5544

THIS FILING IS SUBMITTED ON RECYCLED PAPER

BEFORE THE ILLINOIS POLLUTION CONTROL BOARD

John and Jennifer Fehr-Rankin)
(Property Identification Number) PCB 10-
39-32-100 004)) (Tax Certification)
)

RECOMMENDATION

The Illinois Environmental Protection Agency ("Illinois EPA") hereby files its Recommendation pursuant to Section 125.204 of the regulations of the Illinois Pollution Control Board, 35 Ill. Adm. Code 125.204.

1. On June 9, 2009, the Illinois EPA received a request from John and Jennifer Fehr (log number TC-12-09, Exhibit A) for an Illinois EPA recommendation regarding the tax certification of water pollution control facilities pursuant to 35 Ill. Adm. Code 125.204.

2. The applicant's address is: John and Jennifer Fehr
1450 E. 000N Road
Rankin, Illinois 60960

3. The proposed water pollution control facilities in this request are located at Section 32, T24N, R13W of the 2nd PM in Iroquois County, at the above street address and consist of the following:

Livestock waste management facility consisting of one concrete manure pit (approximately 50 ft. x 156. ft. x 8 ft. deep) with two concrete pump out pits (each approximately 7.75 ft. x 11.25 ft. x 8 ft. deep) and the slotted plastic portion of the floor over the manure pit.

These livestock waste management facilities are used to collect, transport and/or store livestock wastes prior to cropland application, and are further described in Exhibit A.

4. Section 11-10 of the Property Tax Code, 35 ILCS 200/11-10 (2008), defines “pollution control facilities” as:

“any system, method, construction, device or appliance appurtenant thereto or any portion of any building or equipment, that is designed, constructed, installed or operated for the primary purpose of: (a) eliminating, preventing, or reducing air or water pollution ...or (b) treating, pretreating, modifying or disposing of any potential solid, liquid or gaseous pollutant which if released without treatment, pretreatment modification or disposal might be harmful, detrimental or offensive to human, plant or animal life, or to property.”
5. Pollution control facilities are entitled to preferential tax treatment, 35 ILCS 200/11-5.
6. Based on the information in the application and the purpose of the facilities, it is the Illinois EPA’s engineering judgment that the described facilities may be considered “pollution control facilities,” pursuant to 35 Ill. Adm. Code 125.200(a), with the primary purpose of eliminating, preventing, or reducing water pollution, or as otherwise provided in 35 Ill. Adm. Code 125.200, and are eligible for tax certification from the Board.

WHEREFORE, the Illinois EPA recommends that the Board issue the

requested tax certification.

ILLINOIS ENVIRONMENTAL
PROTECTION AGENCY

By: 
Vera Herst
Assistant Counsel
Division of Legal Counsel

Dated: April 13, 2010
Illinois Environmental Protection Agency
1021 North Grand Ave. East.
P.O. Box 19276
Springfield, Illinois 62794-9276
217/782-5544



***** PCB 2010-082 *****
ILLINOIS ENVIRONMENTAL PROTECTION AGENCY

1021 North Grand Avenue East, P.O. Box 19276, Springfield, Illinois 62794-9276 • (217) 782-2829
James R. Thompson Center, 100 West Randolph, Suite 11-300, Chicago, IL 60601 • (312) 814-6026

PAT QUINN, GOVERNOR

DOUGLAS P. SCOTT, DIRECTOR

Memorandum

To: Connie Tonsor, Division of Legal Counsel

From: Al Keller, P.E., Manager, Permit Section

Date: March 19, 2010

Re: John and Jennifer Fehr - Rankin
Recommendation of Tax Certification
Log # TC-12-09
Property Identification # 39-32-100-004

The Bureau of Water received a request on June 19, 2009 from John and Jennifer Fehr for an Illinois EPA recommendation regarding the tax certification of water pollution control facilities pursuant to 35 Il. Adm. Code 125.204. We offer the following recommendation.

The water pollution control facilities in this request include the following:

John and Jennifer Fehr
1450 E 000N Road
Rankin, IL 60960

Section 32, T24N, R13W of the 2nd P.M. in Iroquois County

Livestock waste management facility consisting of one concrete manure pit (approximately 50 ft. x 156 ft. x 8 ft. deep) with two concrete pump out pits (each approximately 7.75 ft. x 5 ft. x 8 ft. deep) with one concrete pump out pit (approximately 7.75 ft. x 11.25 ft. x 8 ft. deep) and the slotted plastic portion of the floor over the manure pit.

This livestock waste management facility is used to collect, transport, and/or store livestock wastes prior to cropland application

These facilities are further described in the enclosed applications and supporting documents.

Based on the information included in this submittal, it is our engineering judgment that the above proposed facilities may be considered "Pollution Control Facilities" under 35 IAC 125.200(a), with the primary purpose of eliminating, preventing, or reducing water pollution, or as otherwise provided in this section, and therefore eligible for tax certification from the Illinois Pollution Control Board. The Bureau of Water therefore recommends that the Board issue the requested tax certification for these facilities.

If you have any questions regarding the above, please contact Keith Runge at 217/782-3362.

SAK:KAR:TC-12-09

cc: Tax Cert File

Rockford • 4302 N. Main St., Rockford, IL 61103 • (815) 987-7760

Elgin • 595 S. State, Elgin, IL 60123 • (847) 608-3131

Bureau of Land – Peoria • 7620 N. University St., Peoria, IL 61614 • (309) 693-5462

Collinsville • 2009 Mall Street, Collinsville, IL 62234 • (618) 346-5120

Des Plaines • 9511 W. Harrison St., Des Plaines, IL 60016 • (847) 294-4000

Peoria • 5415 N. University St., Peoria, IL 61614 • (309) 693-5463

Champaign • 2125 S. First St., Champaign, IL 61820 • (217) 278-5800

Marion • 2309 W. Main St., Suite 116, Marion, IL 62959 • (618) 993-7200

Electronic Filing - Received, Clerk's Office, April 13, 2010

***** PCB 2010-082 Watershed Unit Tax Certification Review Sheet

Project Name: John + Jennifer Fehr
Reviewer: KAR
Log No.: TC-12-09

Location: Rankin
Date: 2-16-10
Type: Agchem
 Livestock

Applicant: John + Jennifer Fehr
1450 E 000N Rd.
Rankin, IL 60960

Contact: 217-397-9936
Phone: _____

Facility: Same as app.

Property ID: ~~39-32-400-004~~

Legal Description: Section 32, T24N, R13W
2nd P.M.

County: Iroquois

Date Control Devices Installed: 10/2006

Provided Fair Cash Value: \$350,000.00

Signature: John Fehr

Title: owner

- Wastes:
- Livestock waste is applied to cropland.
 - Agrichemical rinsate and spillage is recycled through the facility and/or land applied.
 - Other: _____

Physical Description of Pollution Control Devices:

one concrete manure pit (≈ 56 ft. x 156 ft. x 8 ft deep)
w/ 2 concrete pumpouts (each ≈ 7.75 ft x 5 ft x 8 ft deep)
w/ 1 concrete pumpout (7.75 ft x 11.25 ft x 8 ft deep)
with plastic slatted flooring

Other: 3-10-10 spoke with John
The pit and pump outs are 8 ft deep
and all covered concrete.
The flooring is plastic

***** PCB 2010-082 *****

APPLICATION FOR CERTIFICATION (PROPERTY TAX TREATMENT)

POLLUTION CONTROL FACILITY

AIR WATER

ILLINOIS ENVIRONMENTAL PROTECTION AGENCY

P. O. Box 19276, Springfield, IL 62794-9276

This Agency is authorized to request this information under Illinois Revised Statutes, 1979, Chapter, 120, Section 502a-5. Disclosure of this information is voluntary. However, failure to comply could prevent your application from being processed or could result in denial of your application for certification.

FOR AGENCY USE

File No.	Date Received	Certification No.	Date	
Sec. A APPLICANT	Company Name			
	Person Authorized to Receive Certification <i>John + Jennifer Fehr</i>		Person to Contact for Additional Details	
	Street Address <i>1450 E 000N Rd</i>		Street Address	
	Municipality, State & Zip Code <i>Rankin IL 60960</i>		Municipality, State & Zip Code	
	Telephone Number <i>217-397-9936</i>		Telephone Number	
	Location of Facility	Quarter Section	Township	Range
	Street Address <i>Same as above</i>		Municipality <i>Iroq</i>	Township
	Property Identification Number <i>12-R-39-32-400-004</i>		County <i>0</i>	Book Number
	Parcel Number			
Sec. B MANUFACTURING OPERATIONS	Nature of Operations Conducted at the Above Location <i>Facility ID LF0750140000 Iroq. permit No. 4110-06</i> <i>Swine production IL Dept. Ag No.</i>			
	Water Pollution Control Construction Permit No.		Date Issued	
	NPDES PERMIT No.		Date Issued	Expiration Date
	Air Pollution Control Construction Permit No.		Date Issued	
	Air Pollution Control Operating Permit No.		Date Issued	
Sec. C MANUFACTURING PROCESS	Describe Unit Process <i>Feeding weaned pigs</i>			
	Materials Used in Process <i>Corn, Soybean meal, Distillers grains, premixes</i>			
Sec. D POLLUTION CONTROL FACILITY DESCRIPTION	Describe Pollution Abatement Control Facility			

RECEIVED
STATE OF ILLINOIS
JUN 10 2009
Environmental Protection Agency
BUREAU OF AIR

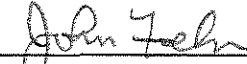
Sec. E	(1) Nature of Contaminants or Pollutants			
	CONTAMINANTS	Material Retained, Captured or Recovered		
		Contaminant or Pollutant	DESCRIPTION	DISPOSAL OR USE
		Hog manure	Liquid	Apply to fields for fertilizer By tractor + tanks with pumps
		(2) Point(s) of Waste Water Discharge		
		None		
	Plans and Specifications Attached		Yes <input type="checkbox"/> No <input type="checkbox"/>	
	(3) Are contaminants (or residues) collected by the control facility?	Yes <input checked="" type="checkbox"/>	No <input type="checkbox"/>	
	(4) Date installation completed <u>10/2006</u> status of installation on date of application _____			
ACCOUNTING DATA	(5) a. FAIR CASH VALUE IF CONSIDERED REAL PROPERTY:	\$ 350000		
	b. NET SALVAGE VALUE IF CONSIDERED REAL PROPERTY:	\$ 1		
	c. PRODUCTIVE GROSS ANNUAL INCOME OF CONTROL FACILITY:	\$ 98000		
	d. PRODUCTIVE NET ANNUAL INCOME OF CONTROL FACILITY:	\$ 2500		
	e. PERCENTAGE CONTROL FACILITY BEARS TO WHOLE FACILITY VALUE:	% 60%		
Sec. F	The following information is submitted in accordance with the Illinois Property Tax Code, as amended, and to the best of my knowledge, is true and correct. The facilities claimed herein are "pollution control facilities" as defined in Section 11-10 of the Illinois Property Tax Code.			
	SIGNATURE	<div style="display: flex; justify-content: space-between;"> <div style="text-align: center;">  _____ Signature </div> <div style="text-align: center;"> <u>Owner</u> _____ Title </div> </div>		
Sec. G	INSTRUCTIONS FOR COMPILING AND FILING APPLICATION			
	General: Separate applications must be completed for each control facility claimed. Do not mix types (water and air). Where both air and water operations are related, file two applications. If attachments are needed, record them consecutively on an index sheet.			
	Sec. A	Information refers to applicant as listed in the tax records and the person to be contacted for further details or for inspection of facilities. Define facility location by street address or legal description. A plat map location is required for facilities located outside of municipal boundaries. The property identification number is required.		
	Sec. B	Self-explanatory. Submit copies of all permits issued by local pollution control agencies. (e.g. MSD Construction Permit)		
	Sec. C	Refers to manufacturing processes or materials on which pollution control facility is used.		
	Sec. D	Narrative description of the pollution control facility, indicating that its primary purpose is to eliminate, prevent or reduce pollution. State the type of control facility. State permit number, date, and agency issuing permit. A narrative description and a process flow diagram describing the <u>pollution control facility</u> . Include a listing of each major piece of equipment included in the claimed fair cash value for real property. Include an <u>average</u> analysis of the influent and effluent of the control facility stating the collection efficiency.		
	Sec. E	List air contaminants, or water pollution substances released as effluents to the manufacturing processes. List also the final disposal of any contaminants removed from the manufacturing processes. Item (1) - Refers to pollutants and contaminants removed from the process by the pollution control facility. Item (2) - Refers to water pollution but can apply to water-carried wastes from air pollution control facilities. Submit drawings, which clearly show (a) Point(s) of discharge to receiving stream, and (b) Sewers and process piping to and from the control facility. Item (3) - If the collected contaminants are disposed of other than as wastes, state the disposition of the materials, and the value in dollars reclaimed by sale or reuse of the collected substances. State the cost of reclamation and related expense. Item (4) - State the date which the pollution control facility was first placed in service and operated. If not, explain. Item (5) - This information is essential to the certification and assessment actions. This accounting data must be completed to activate project review prior to certification by this Agency.		
	Sec. F	Self-explanatory. Signature must be a corporate authorized signature.		
		Submit to:	Attention:	Attention:
		Illinois EPA P.O. Box 19276 Springfield, IL 62794-9276	Al Keller Permit Section Division of Water Pollution Control	Donald E. Sutton Permit Section Division of Air Pollution Control

Application for Pollution Control Facility
submitted by Nancy Elliott, CIAO, contracted
Township Assessor, assessed for 2009, payable 2010.

Phone numbers for John & Jennifer Lehr

217-397-9936

or

815-383-7195

Nancy Elliott, CIAO

815-432-5568

6-8-09



***** PGB 2010-082 *****
ILLINOIS ENVIRONMENTAL PROTECTION AGENCY

1021 North Grand Avenue East, P.O. Box 19276, Springfield, Illinois 62794-9276 • (217) 782-2829
James R. Thompson Center, 100 West Randolph, Suite 11-300, Chicago, IL 60601 • (312) 814-6026

PAT QUINN, GOVERNOR

DOUGLAS P. SCOTT, DIRECTOR

217/782-0610

FEB 23 2010

John and Jennifer Fehr
1450 E 000N Rd
Rankin, IL 60960

Re: Illinois Property Tax Certification
Livestock Waste Management Facilities
Facility ID LF0750140000
IEPA Log No. TC-12-09

Dear Mr. Hofmann:

The application for Illinois Property Tax Certification and supporting documents concerning John and Jennifer Fehr, received on June 10, 2009 have been reviewed and the following is offered for your consideration and appropriate action.

I spoke with Jennifer on February 17, 2010 and requested a description of the facility with dimensions of the manure pit, type of flooring over pit with dimensions, and the type of pump outs. If they are concrete pump outs, please include the dimensions of the pump outs. Please include the legal description with ¼ Section, Township, and Range. I also wanted to confirm the property Id is 12-R-39-32-400-004.

Please submit your response to the Illinois Environmental Protection Agency at the address below to my attention or fax it to 217/782-0610 by March 16, 2010 so that we may complete the review of the subject application. Please include the above log number (TC-12-09) on all correspondence.

Illinois EPA
BOW/Permit Section/ Facility Evaluation Unit
P.O. Box 19276
Springfield, IL 62794-9276

If you have any questions or comments concerning the above items, please contact me at 217/782-0610.

Very truly yours,

Keith Runge
Environmental Protection Engineer
Facility Evaluation Unit
Permit Section
Bureau of Water

KAR:TC-12-09_Tax cert Review letter_10Feb23.docx

cc: KAR

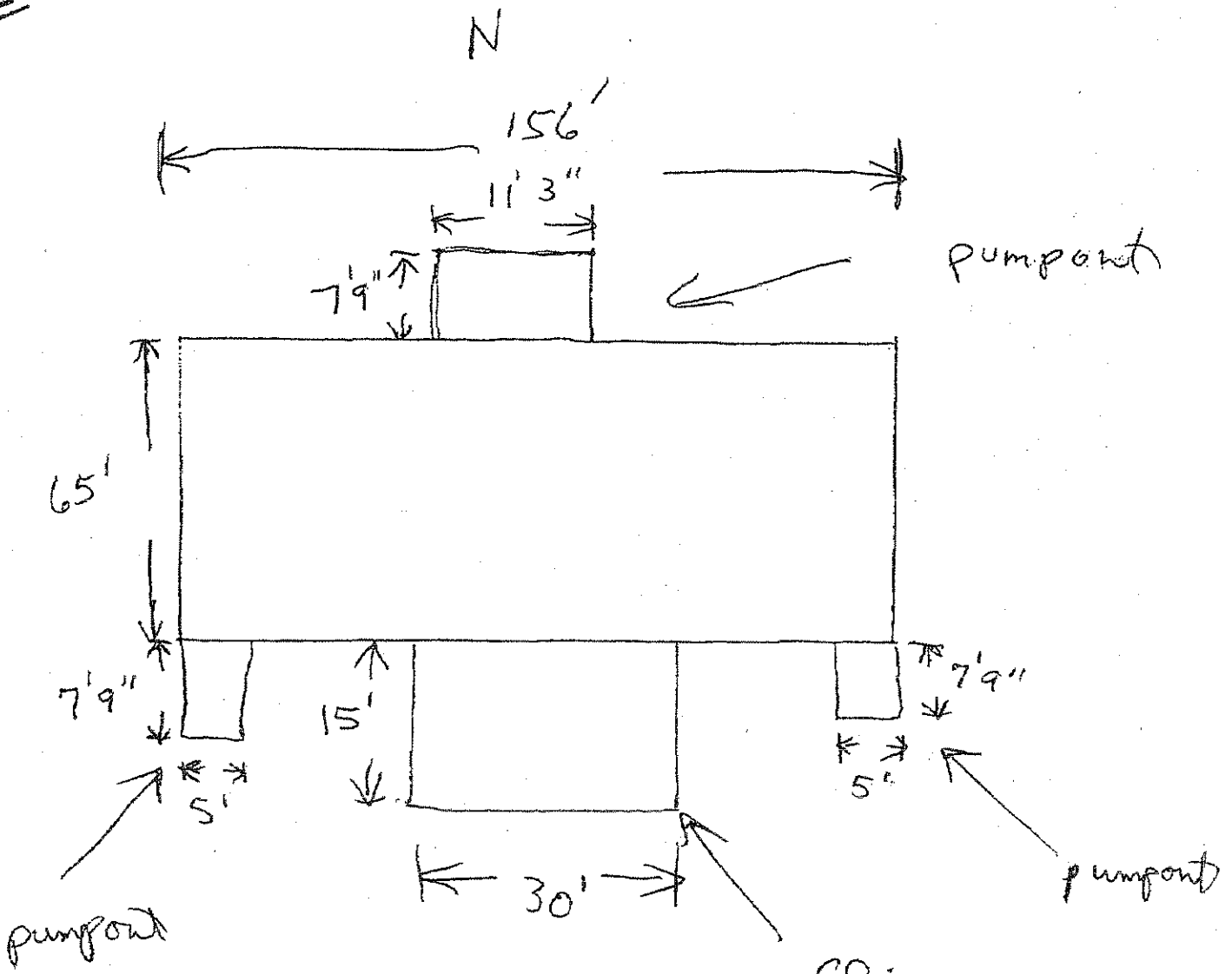

tract 12-260A

PIN No. 39-32-400-004

office / load out

Sec / twr / range
32 24 / 13

Legal Description
S 460' W 245' W 1/2 SE

Log No. (TC-12-09)

Cover Page

To: Keith Runge
Illinois Environmental Protection Agency

From: John Fehr

2 pages including cover

Concerning:

Description of Facility, etc.

ID LF0750140000

IEPA Log No. TC-12-09



ILLINOIS ENVIRONMENTAL PROTECTION AGENCY

1021 North Grand Avenue East, P.O. Box 19276, Springfield, Illinois 62794-9276 • (217) 782-2829
James R. Thompson Center, 100 West Randolph, Suite 11-300, Chicago, IL 60601 • (312) 814-6026

PAT QUINN, GOVERNOR

DOUGLAS P. SCOTT, DIRECTOR

217/782-0610

FEB 23 2010

John and Jennifer Fehr
1450 E 000N Rd
Rankin, IL 60960

Re: Illinois Property Tax Certification
Livestock Waste Management Facilities
Facility ID LF0750140000
IEPA Log No. TC-12-09

Dear Mr. Hofmann:

The application for Illinois Property Tax Certification and supporting documents concerning John and Jennifer Fehr, received on June 10, 2009 have been reviewed and the following is offered for your consideration and appropriate action.

I spoke with Jennifer on February 17, 2010 and requested a description of the facility with dimensions of the manure pit, type of flooring over pit with dimensions, and the type of pump outs. If they are concrete pump outs, please include the dimensions of the pump outs. Please include the legal description with ¼ Section, Township, and Range. I also wanted to confirm the property Id is 12-R-39-32-400-004.

Please submit your response to the Illinois Environmental Protection Agency at the address below to my attention or fax it to 217/782-0610 by March 16, 2010 so that we may complete the review of the subject application. Please include the above log number (TC-12-09) on all correspondence.

Illinois EPA
BOW/Permit Section/ Facility Evaluation Unit
P.O. Box 19276
Springfield, IL 62794-9276

If you have any questions or comments concerning the above items, please contact me at 217/782-0610.

Very truly yours,

Keith Runge
Environmental Protection Engineer
Facility Evaluation Unit
Permit Section
Bureau of Water

KAR:TC-12-09_Tax cert Review letter_10Feb23.docx

cc: KAR

Cover Page

To: Keith Runge
Illinois Environmental Protection Agency
From: John Fehr

2 pages including cover

Concerning:

Description of Facility, etc.
ID LF0750140000
IEPA Log No. TC-12-09

STATE OF ILLINOIS

COUNTY OF SANGAMON

)
)
)
)
)

PROOF OF SERVICE

I, the undersigned, hereby certify that I have served the attached **APPEARANCE AND RECOMMENDATION**, upon the person to whom it is directed, by placing a copy in an envelope addressed to:

Steve Santarelli
Illinois Department of Revenue
101 West Jefferson
Post Office Box 19033
Springfield, Illinois 62794

John and Jennifer Fehr
1450 E. 000N Road
Rankin, Illinois 60960

and mailing it from Springfield, Illinois, on April 13, 2010, with sufficient postage affixed for first class mail; and electronically on April 13, 2010:

Clerk
Illinois Pollution Control Board
James R. Thompson Center
100 West Randolph Street, Suite. 11-500
Chicago, Illinois 60601

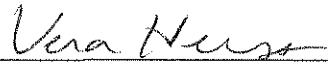

Vera Herst